



Lock Technician Participant Handbook

Table of Contents

S.No.	Modules and Units	Page No.
1.	Introduction	1
	Unit 1.1 - Introduction of the Training Program	3
	Unit 1.2 - Furniture and Fittings Industry in India	6
	Unit 1.3 - Job Role and Responsibilities of a Lock Technician	10
2.	Tools, Equipment and Work Area (FFS/N8501)	15
	Unit 2.1 - Tools, Equipment and Consumables	17
	Unit 2.2 - Safety and Maintenance of Tools & Work Area	46
3.	Maintain Health, Safety and Security at Workplace (FFS/N8601)	53
	Unit 3.1 - PPE – Personal Protective Equipment	55
	Unit 3.2 - Identify and Deal with Workplace Hazards	62
	Unit 3.3 - Personal Health and Hygiene	81
4.	Basics of Lock Installation Activities	89
	Unit 4.1 - Doors and Windows	91
	Unit 4.2 - Types of Lock and Lock Systems	112
	Unit 4.3 - Basic Mathematical Skills	121
	Unit 4.4 - Measuring Systems	129
	Unit 4.5 - How to Use Basic Tools Required for Lock Installation	133
5.	Carry out Lock Installation Activities (FFS/N5703)	153
	Unit 5.1 - How to Install a Rim Lock	155
	Unit 5.2 - How to Install a Mortise Lock	162
	Unit 5.3 - How to Install a Deadbolt/Cylindrical Lock	168
6.	Perform Lock Repairing and Servicing (FFS/N5704)	177
	Unit 6.1 - Identify and Rectify the Common Faults in Locks	179
7.	Carry out Work Effectively at Workplace (FFS/N8701)	191
	Unit 7.1 - Workplace Policies and Procedures	193
	Unit 7.2 - Communication Skills	197
	Unit 7.3 - Work Effectively with Others at Workplace	205



1. Introduction

Unit 1.1: Introduction of the Training Program

Unit 1.2: Furniture and Fittings Industry in India

**Unit 1.3: Job Role and Responsibilities of a
Lock Technician**

Key Learning Outcomes

At the end of this module, you will be able to:

1. Know what this training program is about
2. Know about Indian furniture and fittings industry, its size, key growth drivers and market structure
3. Know about employment opportunities in Indian furniture and fittings industry
4. Define your roles and responsibilities as a lock technician
5. Know about the career progression for a lock technician
6. Know about the technical and essential skills required to become an efficient lock technician



- Problems or faults in locks
- Repairing and servicing of locks
- Maintenance and safety of tools and equipment
- Maintaining the workplace clean, organized and safe
- Environmental health and safety
- Policies and procedures, and rules and regulations of an organization
- Core skills/generic skills/professional skills and technical skills required to perform the job in efficient manner

1.1.2 Objectives of the program

After completing this training program, you will have the skills to:

- Work in a fittings and fixtures company or furniture manufacturing company as a Lock Technician
- Work in a safe and secure manner
- Adhere to safety and security guidelines
- Comply with all guidelines and policies of the organization
- Maintain safe, hygienic and secure working environment
- Carry out lock installation activities efficiently and perfectly
- Identify and perform lock repairing and servicing
- Identify and select appropriate tools and equipment to complete the job
- Use tools and equipment in appropriate manner
- Handle and maintain tools and equipment in correct and safe manner
- Organize the work area using appropriate methods
- Observe any safety hazards, conditions or unsafe practices at workplace
- Communicate effectively at workplace
- Maintain better workplace relationship
- Possess the right personal qualities, attributes and hygiene for the job

UNIT 1.2: Furniture and Fittings Industry in India

Unit objectives

After completing this unit, you will be able to:

1. Know the overview of furniture and fittings industry in India
2. Know the Indian furniture industry size and key growth drivers
3. Understand Indian furniture market structure
4. Know about the employment opportunities in Indian furniture and fittings industry

1.2.1 Furniture industry in India

The size of the Indian furniture retail market is increasing. As of 2006, the Indian furniture market is estimated to be worth US\$ 7,922 million. In fact, Global furniture industry research and consulting firm, CSIC Milano has classified India as one of the 14 large furniture markets in the world.

Key features of Indian furniture industry

- This industry makes a marginal contribution of 0.5 per cent of the total Gross Domestic Product (GDP).
- Demand for furniture in India surged at 12% annual rate over 2009-2012, and in 2013 it increased at a rate of 15%.
- The major part of this industry, about 85%, is in the unorganized sector.
- The remaining 15% is in organized sector, which is expected to grow by 20 percent a year.

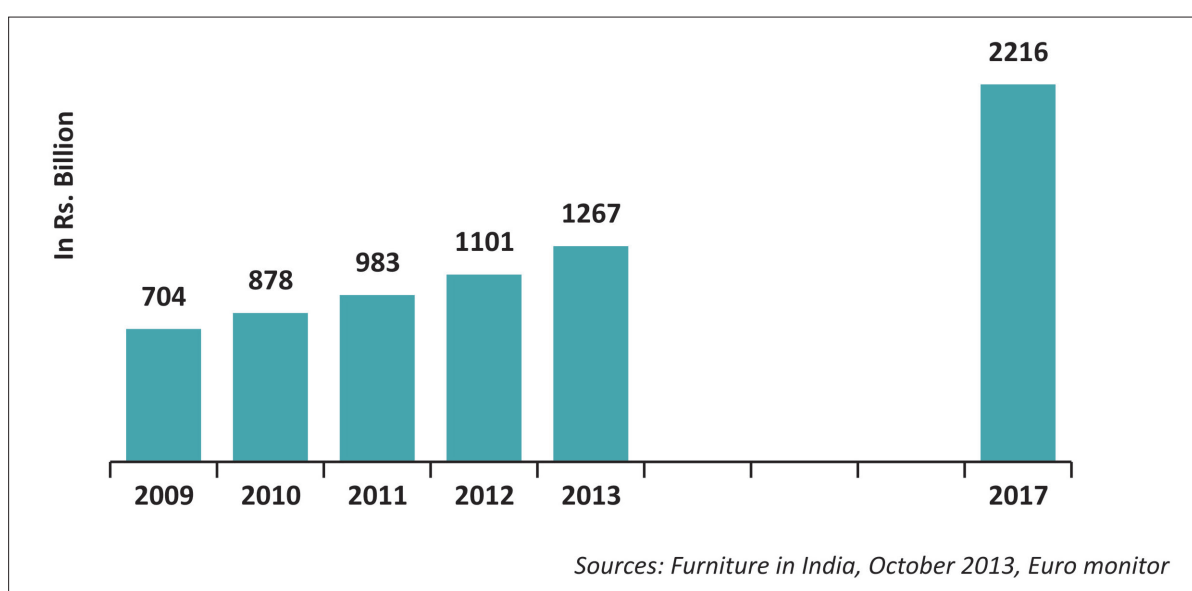

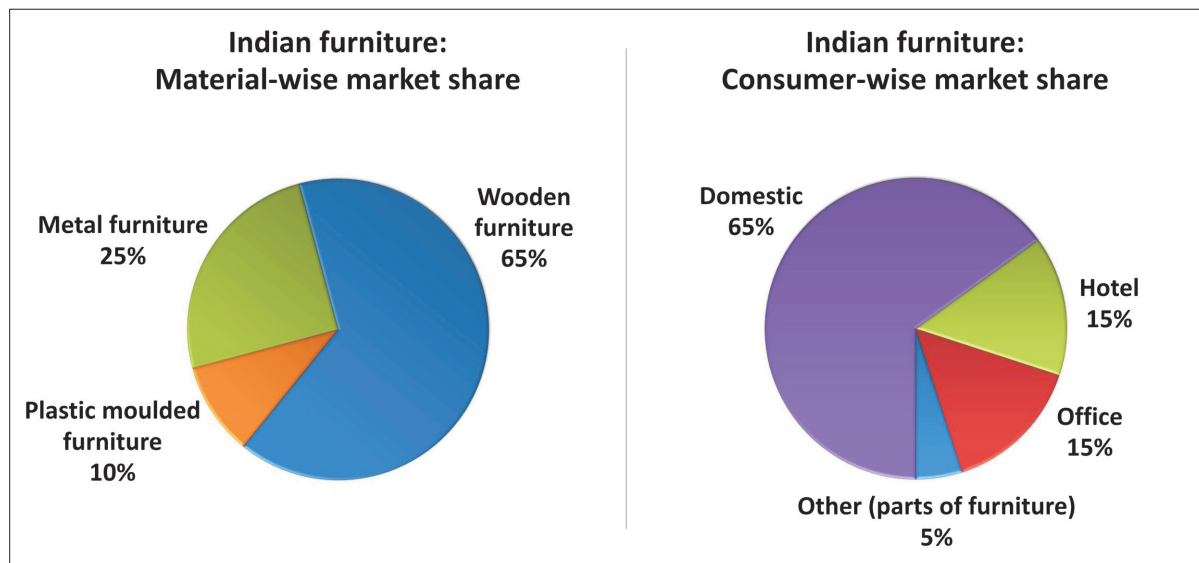

- Organized sector comprises of leading manufacturers, importers and dealer/distributors. Some leading Indian furniture brands are Godrej & Boyce Manufacturing Co. Ltd., Furniturewala, Zuari, Yantra, Renaissance, N R Jasani & Company, Furniture Concepts, Durian, Kian, Millenium Lifestyles, Truzo, Featherlite, etc.
- The sector currently employs over 4.11 million employees and is slated to employ more than 11.29 million employees by 2022.
- The period 2017-22 will see a higher growth in employment vis-a-vis 2013-17 due to expected changes in consumer preferences and penetration of organized furnishing services in tier-I and tier-II towns.
- Some of the major segments in furniture industry are residential, office, contract and institutional.
- There are other segments also based on the application (kitchen, bathroom, bedroom, and others) or on the raw material (wooden, plastic, metal, bamboo, and others).
- Home furniture is the biggest segment in the Indian furniture market, accounting for about 65 per cent of sales.
- Wooden furniture is the largest segment which accounts for about 65 per cent of total production.

Key Demand Drivers

The key drivers that have had a significant impact on the industry are:

- Real estate/housing boom
- Tourism and hospitality industry growth
- Increasing growth in IT, telecom and retail sectors
- Changing consumer demographics

1.2.2 Architectural hardware and fittings market in India

The furniture industry also includes architectural hardware and furniture fittings, like doorknobs, handles, pulls, latches, locks, glass product fittings, etc. Architectural hardware and fittings have come a long way from its use as a mere functional accessory to a decorative hardware and fittings that give a unique look and appearance to the furniture products. Today, hardware and fittings come in an extensive range of designs, styles, sizes and finishes to satisfy every need.

In terms of technical development of the industry, it is shifting from manual labour to machines including raw material testing, superior finishing and improved mechanisms. Manufacturers now utilize technology to develop light weight fittings that make less noise and can be operated smoothly. Consumers are also more aware and educated about the importance of fittings in the building and are looking for high quality products. While, commercial clients want durable fittings that can withstand high usage, the homeowner want value for money as their homes are one-time investments.



Some leading door and furniture lock brands are Godrej, Dorma, Ozone, Ebco, Hafele, Hettich, Dorset, Jainson, Nova, Link, Euroset, etc.

Exercise

1. The key factors to the growth of Indian furniture and fittings industry are –
 - a) Changing lifestyle
 - b) Development in real estate
 - c) Increasing demand of offices
 - d) All of above
2. Which type of furniture is manufactured the most?
 - a) Plastic moulded furniture
 - b) Wood furniture
 - c) Steel furniture
 - d) Cane furniture
3. Which segment demands furniture the most?
 - a) Office
 - b) Hotel
 - c) Home
 - d) Hospital

UNIT 1.3: Job Role and Responsibilities of a Lock Technician

Unit objectives

After completing this unit, you will be able to:

1. Know and Understand the job role of a lock technician
2. Understand the responsibilities of a lock technician
3. Know and understand the essential skills required for the job of a lock technician

1.3.1 Who is a lock technician?

A lock technician is a skilled wood worker who works with locks on doors and furniture. S/he, also known as locks technician, is responsible for installations of different locks on the door and furniture. S/he also does repair, adjust and service of locks whenever required.

1.3.2 What does a lock technician do?

A lock technician possesses the skill and knowledge in installing and repairing locks and locksets. She/he works in commercial or residential buildings where physical security is required to protect them from unauthorized entry.

A lock technician:

- Identifies the type of lock as per design and functioning of the door/window.
- Chooses right tools for lock installation and repair work.
- Uses tools in correct and safe manner.
- Reads and interprets the templates for lock installation.
- Does marking on door/window as per instructions given in the lock template.
- Installs locks on door/window in correct manner.
- Checks functionality of lock by using the key.
- Cleans the work area to prevent accidents.
- Identifies the possible problems/faults in the lock as per the complaints of the customer.
- Visually checks the lock for any fault.
- Identifies the cause of the problem/fault based on the inspection.
- Dismantles the lock if required and repairs the lock by changing the defective component of the lock.

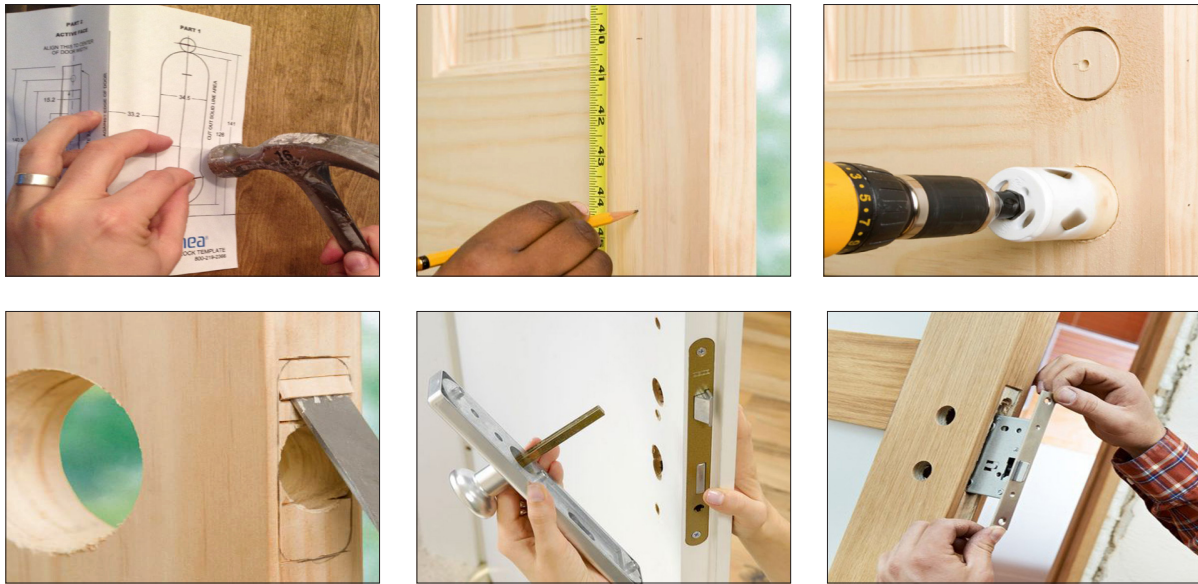

- Reports the problem to retailer/company, if lock cannot be repaired and the problems persist.
- Seeks clarifications from supervisor or other authorized person in case of risk or doubt.
- Identifies and reports any hazards and potential risks/threats to supervisor or other authorized person.
- Undertakes first aid related to fractures, cuts, bleeding, burn and electrocution, if asked to do so.
- Takes appropriate action in case of fire emergency.
- Reports to her/his supervisor for damaged/broken tools and equipment, or any accident occurred at workplace.

1.3.3 What are the responsibilities of a lock technician?

A lock technician is also responsible for:

- Carrying out work functions in accordance with the norms of the organization and workplace
- Working as per organizational policies and procedures
- Safe and correct handling and storage of materials, tools and equipment
- Proper disposal of waste
- Following different ways of minimizing waste
- Following safety procedures while operating power tools
- Maintaining a clean and hazard free working area
- Safe and correct use of tools and equipment
- Following safe work practices

- Using safety equipment and personal protection equipment at workplace
- Completing allocated tasks within the desired time frame and quality standards
- Displaying courteous behavior at workplace at all times

1.3.4 What is required to become an efficient lock technician?

A lock technician requires training which involves acquiring both knowledge and physical practice. An efficient lock technician should have technical knowledge and skills to perform her/his jobs. Some basic technical skills are –

- Reading the measuring tools
- Accurate Measuring and marking on doors
- Operating tools, such as screwdriver, power drill and chisel
- Checking level of the work done
- Mathematical skills

In addition to essential technical knowledge and skills, a lock technician should also possess certain soft skills, or personal qualities –

- | | |
|--|--------------------|
| ▪ Communication and interpersonal skills | ▪ Personal hygiene |
| ▪ Detail oriented | ▪ Honest |
| ▪ Work in a team | ▪ Trustworthy |
| ▪ Problem solving | ▪ Hard working |
| ▪ Punctual | ▪ Courteous and |
| ▪ Hand and eye coordination | ▪ Dedicated |
| ▪ Physical fitness | ▪ Calm |

In this training program, you will be trained in technical and professional skills required to become an efficient lock technician.

1.3.5 What is the workplace of a lock technician like?

A lock technician generally works on commercial and residential projects. Her/his work is closely associated with furniture industry. The lock technician works internally and externally, including in the homes of customers and on building sites in all weather conditions.

Every step in the lock installation process matters; mistakes are largely irreversible and have a very high cost. This means that the lock technician must work safely and tidily, have stamina, have good hand-eye coordination, concentrate and pay attention to detail in order to achieve an excellent result.

1.3.6 Future prospects for a lock technician

There are good job opportunities for trained and skilled lock technicians. A trained and skilled lock technician can work with lock manufacturers, retailers, service companies, or furniture manufacturers.

Installing locks and working with wood is a hand skill. The more you will practice, the more you will be skilled in this art. Only you need is hard work, dedication, determination and honesty towards your job. Dedication and hard work displayed in your work will prove that you have the necessary passion and drive to succeed at the next level.

Exercise

Choose the correct answer –

1. A lock technician's work includes –

1. Make door frames
2. Make a chair
3. Install a rim lock
4. 4. 1 and 3

2. A lock technician's job does not include –

1. Drill holes in door
2. Check vehicles in a complex
3. Read lock template
4. Chisel out the mortise in door

3. What personal qualities should an efficient lock technician have?

1. Honesty
2. Dedication to work
3. Hard work
4. All of above

4. A lock technician is responsible for –

1. Maintain a safe and secure workplace
2. Follow safe work practices
3. Follow organization's work policies
4. All of above



2.1.1.2 Marking tools

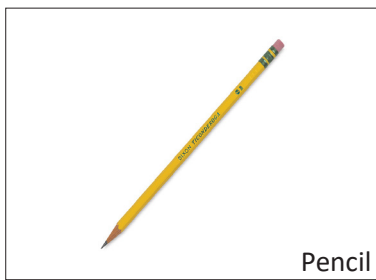

Pencil



Scratch Awl



Marking Gauge

Pencil –

- It is used to mark guidelines on wood for cutting.
- It is also used to make drawing and write measurements.
- Normally 2H pencils are used, which are very hard and can write or mark almost on any surface.

Scratch Awl –

- It is a tool, which is used for layout and point making.
- It is used to scribe a line.
- It is a steel spike which marks a fine groove on wood.

Marking Gauge –

- It is used for marking parallel lines on wood.
- It has two main parts – stock and beam. Stock is made of wood. It has a square hole in which wooden beam slides. Stock has a hole at one end. A thumb screw is fitted in it, which controls the beam.
- There is a pin at one end of beam which makes marking on wood.



Mortise Gauge



Divider

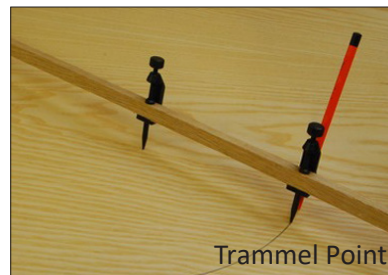

Trammel Point

Mortise Gauge –

- It is a very common tool for marking.
- It is same as marking gauge, but it has two pins.
- It is made of a fence like support, which can be locked and moved on a beam for marking.

Divider –

- It is a two-legged tool and the ends of these legs are pointed.



STEP 7: Remove the screws from the lock body to release the retainer plate (mounting plate).

STEP 8: On the inside, position the retainer plate of the lock body over the hole and connect it to the cylinder using the screws provided with lock set. Depending on the thickness of the door, you may need to shorten the length of the screws. Use a hacksaw to cut the screws.

STEP 9: Align the arrows on the back of the lock body and place onto the retainer plate and position it in place. Ensure that the connecting bar fits into the slot in the back of the lock body.



STEP 10: Now, mark the outline of the recess on the edge of the door with a pencil.

STEP 11: Remove the lock body and chisel out the recess to the required depth (usually it is 3 mm).



STEP 12: Place the lock body in position so that it sits in the recess you have just cut out. Mark the position of the screws.

STEP 13: Drill pilot holes for each screw.



STEP 14: Reposition the lock body on the door and secure it into place by driving the screws.

STEP 15: Close the door and place the receptacle at the edge of the door jamb. Use a pencil to mark the screw positions on the door jamb.

STEP 16: Mark the outline of the recess on the inside face of the jamb.

STEP 17: Chisel out the recess so that when the receptacle is fitted there is no more than a 5mm gap between it and the lock body.

STEP 18: Drill pilot holes before screwing the receptacle onto the door jamb.



STEP 19: Position the receptacle on the jamb and screw it to the frame.

STEP 20: Lock and unlock the lock several times to check if the lock operates smoothly.

Tips

- Do not forget to wear personal protective equipment.
- Keep in mind that if you only drill from one side of the door, you'll end up splintering the wood when the drill bit emerges on the other side. To avoid this, drill through halfway from the inside, and then drill through the centre mark on the exterior side of the door until you have created a hole right through the door.
- Ensure that the orientation of the keyhole is correct. Keyhole should be vertical, so that the connecting bar remains horizontal. Then only it will fit in the back of the lock body.
- After having cut the connecting bar, its edges should be filed for proper functioning.
- It is advisable to place the receptacle slightly lower than the lock body to take care of door sag in future.
- Always drill a pilot hole before driving the screws into the door; it will help the screw hold in its position while driving it.
- Always check the level of retainer plate, lock body and receptacle before tightening the screws.
- Always refer to the manufacturer's installation instructions.
- Refer to the marker to know the diameter of the holes and choose the drill bits as per the size.

UNIT 5.2: How to Install a Mortise Lock

Unit objectives

After completing this unit, you will be able to:

1. Mark out the position of the lock and strike plate
2. Position and mark out the mortise for lock body
3. Remove the wood for the lock body and recesses
4. Drill the holes for spindle and keyhole
5. Position and fit the lever set and strike plate in place

5.2.1 Step-by-step installation of a mortise lockset

Tools/equipment/material needed:



Measuring tape



Pencil



Try square



Awl or Centre punch



Mallet



Hammer



Wide and mortise chisels



Rasp file



Power drill



Drill bits



Spade bits



Screwdriver



Masking tape



Sandpaper



PPE

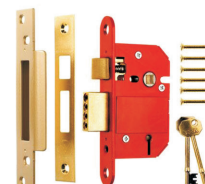

Mortise lockset

Parts of a mortise lock

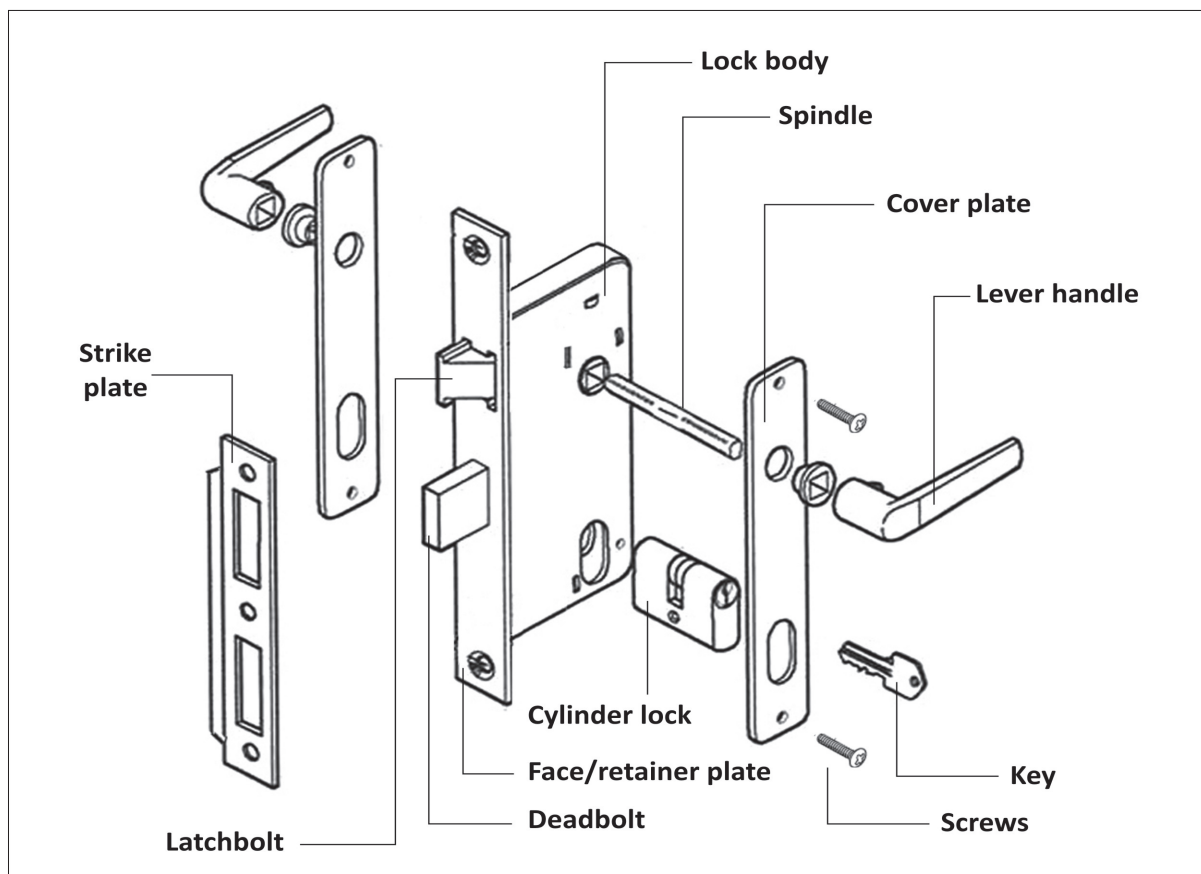

Note:

■ **Preparing for lock installation**

Place wedge under the door to secure it or remove the door from door frame and place it on edge with the lock side up, securing it with a clamp.

■ **Determining the height for the lock**

Mortise lock is installed about 1050 mm from the floor. This will be center of the handle.

■ **Adjusting the lock**

If the latch of the lock faces the wrong way for the opening direction of the door, you will need to turn it round. At the side of the lock body is a small pin which you can push upwards with a narrow screwdriver. The latch will then fall forwards out of the lock body. You can then turn it round to face the other direction and push it back into place.

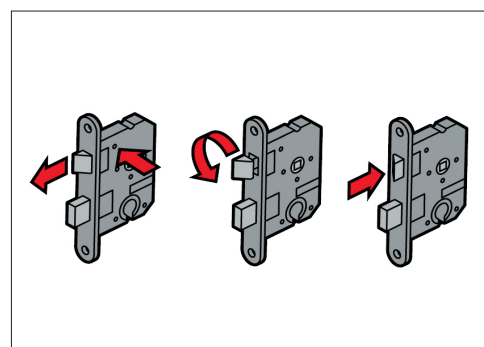

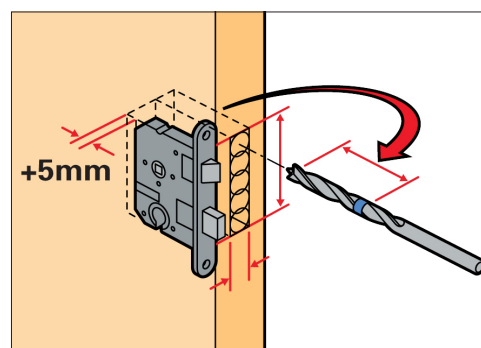
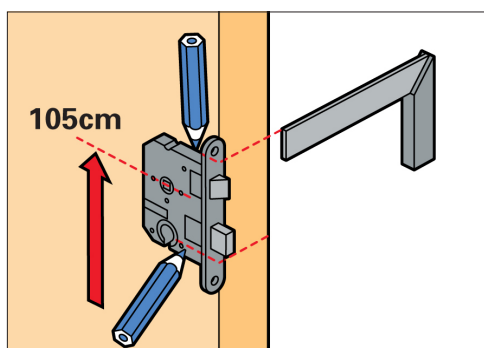

STEP 1: Mark out the position of the lock

Hold the lock body in position against the face of the door, and mark out the positions of the top and bottom of the lock body with a pencil on the left or right side of the door. Always keep an extra margin of 6 mm. You can refer to the lock marker or template for exact size of mortise pocket. Extend the lines you have marked to the narrow edge of the door using a try square. Once marking is done on the door edge, draw the vertical center line between them. Place the back of the lock body on the center line and mark out the shape of the lock body with a pencil. This outline now shows where the recess has to be cut in the door edge.

STEP 2: Drill out the mortise in the door

Select the drill bit, roughly 2 mm thicker than the lock body. Measure the total depth of the lock body including the retaining plate, which is recessed into the door edge. Mark the length of the lock body on the drill bit with a strip of tape. This will give you a rough guide as to how far you need to drill into the door. Keep an extra margin of 5 mm. Now, using centre punch, mark a series of points along the centre line and drill the holes on the marked points.

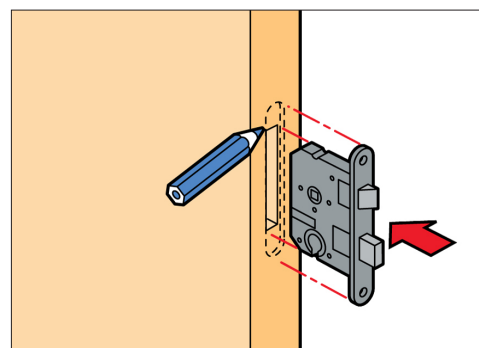
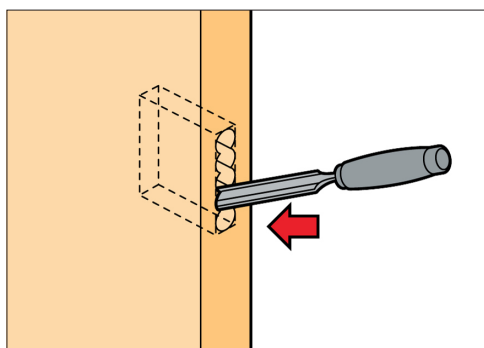

STEP 3: Finishing mortise with a chisel

Once drilling is done, you can finish the edges in a straight line with a chisel. Pare out the wood with the chisel, joining up the drilled holes to create a mortise. Finish the mortise neatly until it is exactly the right shape for the lock body.

STEP 4: Mark out the retaining plate

Once you have fitted the lock body in the mortise, mark out the edge of the retaining plate with a pencil. Remove the lock from the mortise.

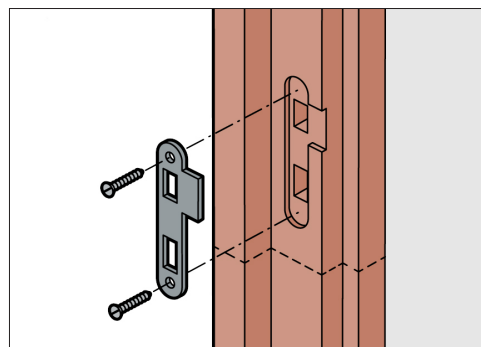
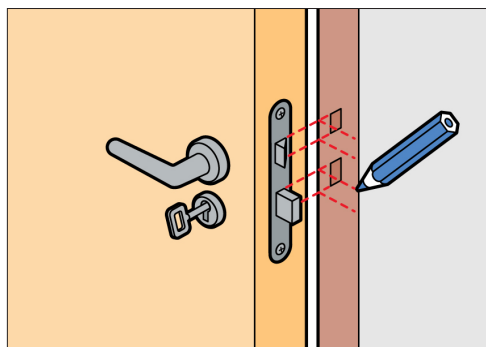

STEP 9: Mark out the strike plate on the door frame

Turn the key so the locking bolt protrudes from the lock, and hold the door against the door frame. Use a sharp pencil to mark lines on the door frame at the top and bottom of the locking bolt and the latch. Then with the door open you can extend these lines across the inside of the door frame. With these lines as a guide, you can use the strike plate as a template. Then you can easily mark out the overall outline of the strike plate and the recesses for the latch and locking bolt. Add approximately 1 mm clearance from the mark. Make sure that the marks are level and plumb.

STEP 10: Drill out the sockets for latch and locking bolt

The depths of the mortises in the door frame must be equal to the lengths of the latch and locking bolt. Cut out these sockets deeply enough so the latch and locking bolt can fall into them fully.

STEP 11: Make a recess for the strike plate

Pare out the wood with a chisel to recess the strike plate together with its protruding lip. The outer face of the strike plate should be flush with the edge of the door frame. Fix the strike plate to the door frame with screws. If strike box (dust box) is supplied with the lockset, insert it into the socket before fixing the strike plate. Test the locking mechanisms to make sure the strike plate align.

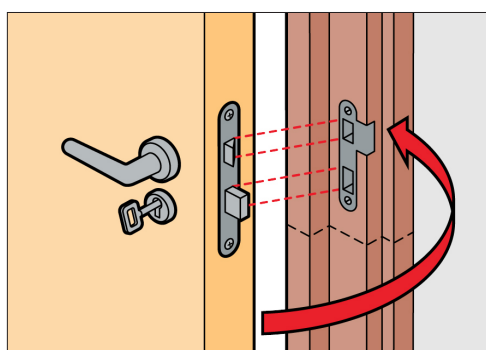

STEP 12: Bend over the lip of the strike plate

You can carefully bend over the lip of the strike plate with a small hammer, so that it neatly follows the contour of the door frame. The lip is meant to protect the door frame from the impact of the latch, each time the door closes.

STEP 13: Inspect the lock

Mortise lock is now installed. Check that the lock works smoothly and engages correctly with the strike plate on the door frame.

UNIT 5.3: How to Install a Deadbolt/Cylindrical Lock

Unit objectives

After completing this unit, you will be able to:

1. Mark out the position of the lock and strike plate on door and jamb
2. Drill the holes for latchbolt and lock cylinder
3. Remove the wood for recesses using the chisel
4. Position and fit the latchbolt, lock cylinder and strike plate in place

5.3.1 Step-by-step installation of a cylindrical lock

Tools/equipment/material needed:



Measuring tape



Pencil



Try square



Awl or Centre punch



Hacksaw



Hammer



Chisel



Sandpaper



Power drill



Hole saw



Spade bits



Screwdriver



Masking tape



PPE



Deadbolt lock or Cylindrical lock

Parts of a deadbolt lock

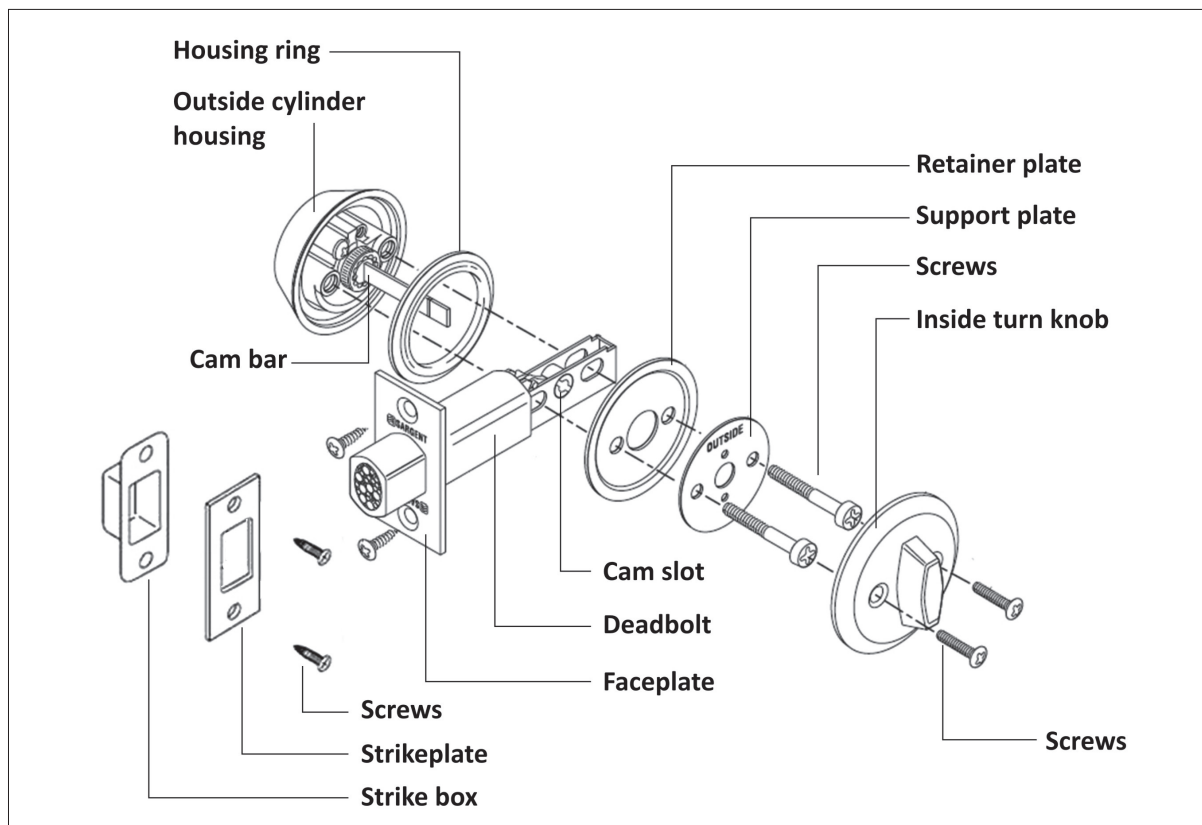

Parts of a cylindrical lock (knob)

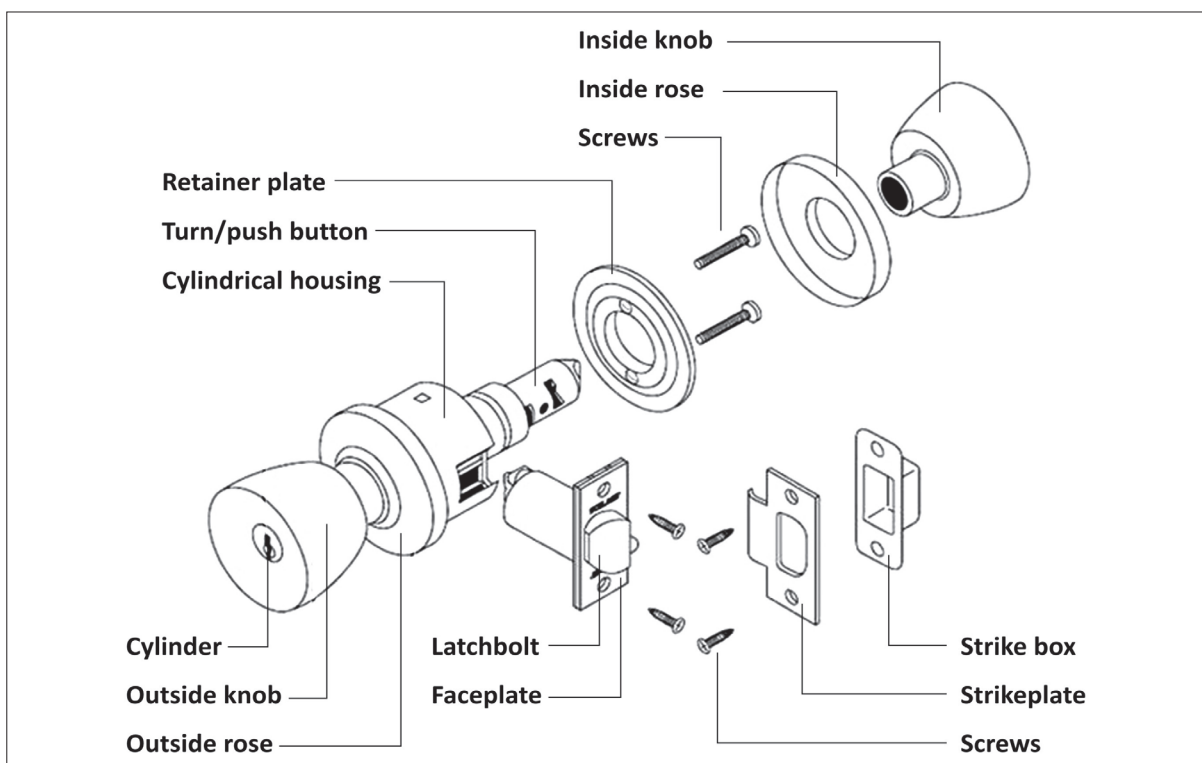

Part of a cylindrical lock (lever handle) type 1

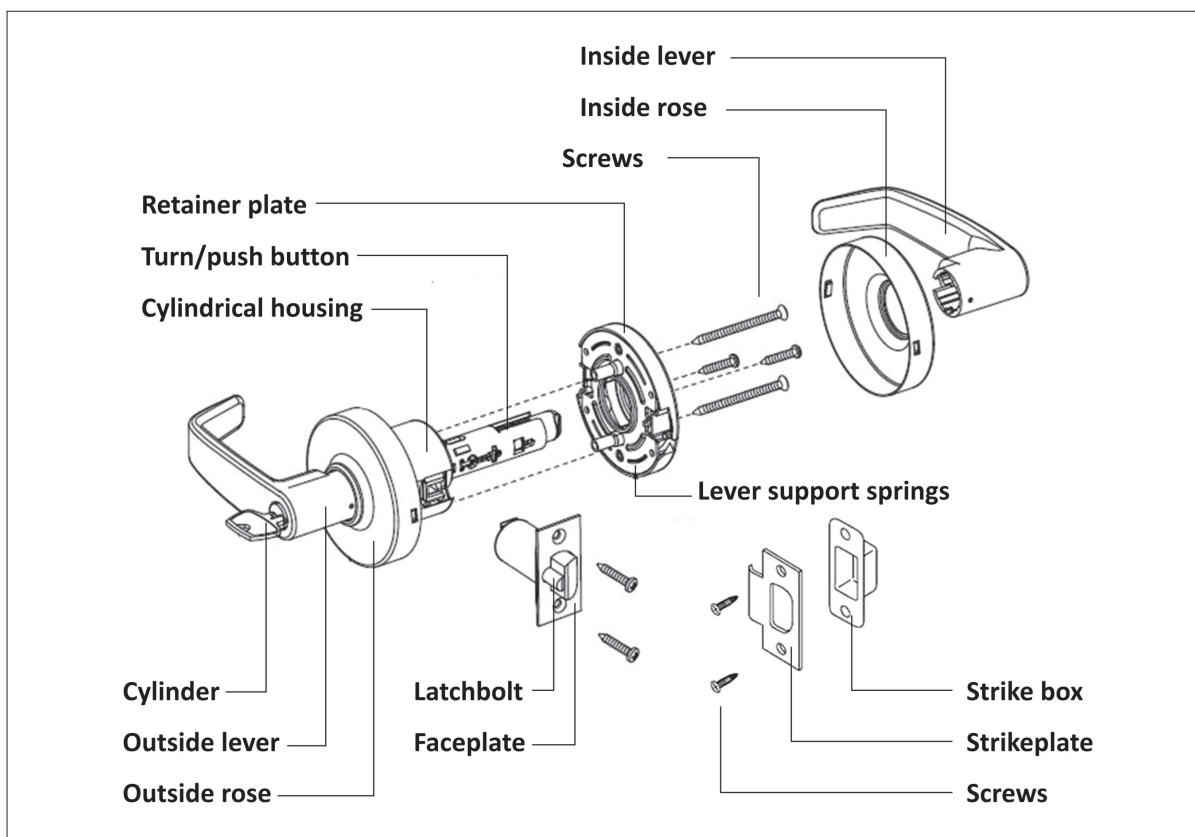

Part of a cylindrical lock (lever handle) type 2

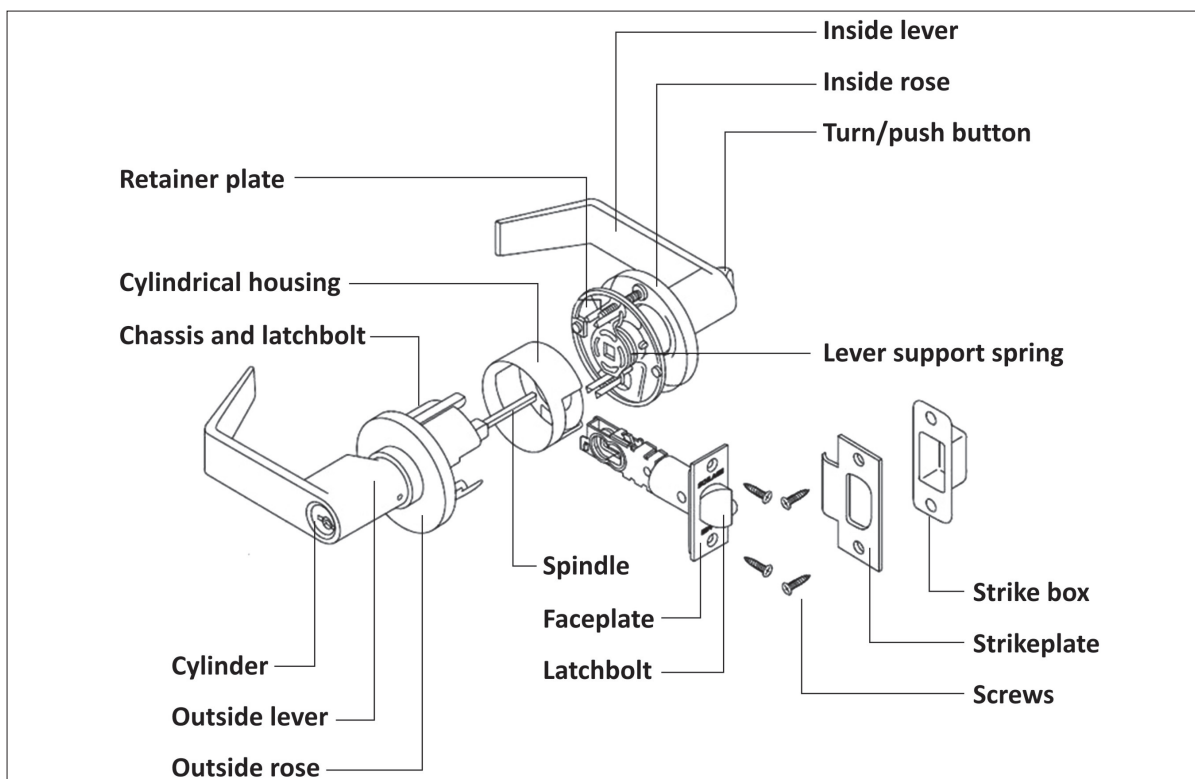

7.3.5 Making right decision

One good professional skill you must have is the skill to make right decisions. As an efficient lock technician, you are responsible to deliver high quality work. At workplace, you will have to make many decisions, such as choosing right lock to install, taking appropriate decisions related to responsibilities, identifying the problem and applying appropriate methods of rectification, assessing for any damage/faulty component in the equipment/machine and taking action accordingly, making appropriate timely decision in responding to emergencies/accidents, etc.



7.3.6 Keeping your skills and knowledge fresh

The furniture industry is experiencing rapid changes due to technological advancements. Manufacturers keep introducing new materials, new tools new finishes, new hardware and new fittings. As an efficient lock technician, you should be aware of new techniques and new fittings. Some manufactures also organize training sessions to introduce new tools and new techniques. You should be in touch with all these to enhance your skills and knowledge.

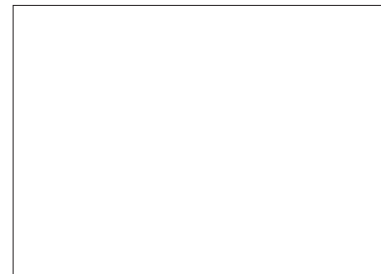

Exercise

1. What are the benefits of working as a team member?
 - a) Work gets completed in time
 - b) Client gets high quality work
 - c) Client gets satisfied
 - d) All of above
2. If you want to complete your job in time, you should –
 - a) Gossip with your friend on phone during work hours
 - b) Take rest for two hours after lunch break
 - c) Go for a walk with your friends
 - d) None of above
3. To deliver something new to your client, you should –
 - a) Have knowledge about new techniques
 - b) Know about new materials available in the market

- c) Be aware of new trends of market
- d) All of above

4. What are the time robbers at workplace?

- a) Chat on phone
- b) Long tea breaks
- c) Gossip with co-worker
- d) None of above

5. To resolve conflict with your co-worker, you should –

- a) Talk with your co-worker
- b) Listen to your co-worker
- c) Get angry with your co-worker
- d) 1 & 2

Notes

.....

.....

.....

.....

.....

.....

.....

.....

.....

.....

.....

.....

.....

.....

.....

.....

.....

.....

.....

.....

.....

.....

.....